

Solid carbide twist drill (without step)

Please copy, complete and return (only 1 tool per enquiry questionnaire/order).



Enquiry Order



Company		Customer number (if available)
Contact partner	Tel./Fax	E-Mail
Address		

MAPAL Inc.
4032 Dove Road
48060 Port Huron MI
USA
Phone +1 / 8 10 / 3 64 80 20
Fax +1 / 8 10 / 3 64 47 50
info@us.mapal.com
www.mapal.us

Number of drills _____ Delivery date required (non-binding) _____ Week

Please describe your machining task for us and the special tool you require:

Material to be machined:

- | | | | |
|-------------------|------------------------------------------------------------------------------------|---------------------------------------------------------|--------------------------------------------------------|
| Bore: | <input type="checkbox"/> Through hole | <input type="checkbox"/> Unalloyed steel | <input type="checkbox"/> Aluminium (Si content > 10 %) |
| | <input type="checkbox"/> Blind bore | <input type="checkbox"/> Cast steel | <input type="checkbox"/> Aluminium (Si content < 10 %) |
| Machining method: | <input type="checkbox"/> wet <input type="checkbox"/> dry | <input type="checkbox"/> Alloyed steel | <input type="checkbox"/> Copper |
| | <input type="checkbox"/> min.lubrication | <input type="checkbox"/> Inox | <input type="checkbox"/> Brass |
| Coolant supply: | <input type="checkbox"/> Ext. <input type="checkbox"/> Int. | <input type="checkbox"/> Stainless/acid-resistant steel | <input type="checkbox"/> Bronze |
| |  | <input type="checkbox"/> Grey cast iron | <input type="checkbox"/> Titanium alloys |
| |  | <input type="checkbox"/> Alloyed grey cast iron | <input type="checkbox"/> Nickel alloys |
| | | <input type="checkbox"/> Nodular iron | <input type="checkbox"/> Chilled cast iron |
| | | <input type="checkbox"/> CGI | <input type="checkbox"/> Hardened steel |
| | | <input type="checkbox"/> Malleable iron | <input type="checkbox"/> _____ |

Hardness (HRC, HB, etc.): _____ Tensile strength (N/mm²): _____ Standard: _____ Standard No.: _____

MAPAL code (e.g. M1504, if known): _____

Cutting direction: R.H. L.H.
(if not stated we will assume R.H.)

Coating:
(if you wish to choose yourself)

- MxF
 MxH
 TiAlN
 uncoated

Shank form:

- HA (DIN 6535) 
 HB (DIN 6535) 
 HE (DIN 6535) 

Date _____ Signature _____

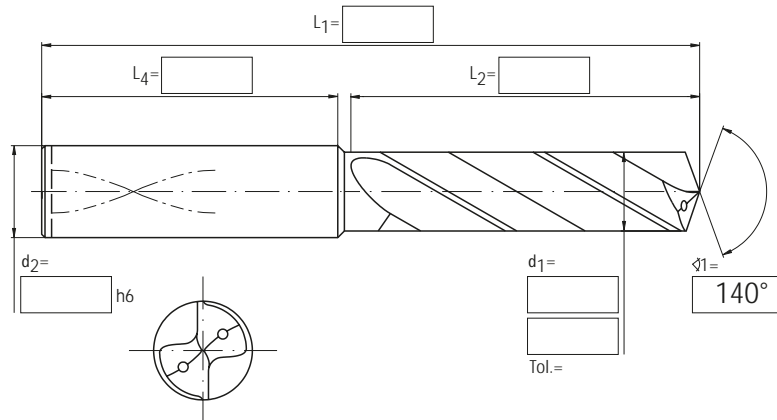

Please do not write in this box, which will be completed by MAPAL specialists.

- | | | |
|------------------------------------------------------------------------------------------------------------------------------------------------------------------------------|--------------------------------------------------------------------------------------------------------------------------------------------------------------------------------|--------------------------------------------------------------------------------------------------------------------------------------------------------------------------------------------------------------------|
| Groove form: <input type="checkbox"/> MEGA
<input type="checkbox"/> GG
<input type="checkbox"/> ALU
<input type="checkbox"/> INOX
<input type="checkbox"/> _____ | Coating: <input type="checkbox"/> MxF
<input type="checkbox"/> MxH
<input type="checkbox"/> TiAlN
<input type="checkbox"/> uncoated
<input type="checkbox"/> _____ | Radial land on face: <input type="checkbox"/> Radial land on taper surface
<input type="checkbox"/> Radial land on 4 faces

<input type="checkbox"/> Round point
<input type="checkbox"/> Spiral point |
|------------------------------------------------------------------------------------------------------------------------------------------------------------------------------|--------------------------------------------------------------------------------------------------------------------------------------------------------------------------------|--------------------------------------------------------------------------------------------------------------------------------------------------------------------------------------------------------------------|

Blank (MC): _____