

# Solid carbide drill, straight fluted (without step)



Please copy, complete and return (only 1 tool per enquiry questionnaire/order).

Enquiry                       Order

**MAPAL Inc.**  
4032 Dove Road  
48060 Port Huron MI  
USA  
Phone +1 / 8 10 / 3 64 80 20  
Fax +1 / 8 10 / 3 64 47 50  
info@us.mapal.com  
www.mapal.us

Company _____		Customer number (if available) _____
Contact partner _____	Tel./Fax _____	E-Mail _____
Address _____		

Number of drills \_\_\_\_\_ Delivery date required (non-binding) \_\_\_\_\_ Week \_\_\_\_\_

Please describe your machining task for us and the special tool you require:

Material to be machined:

- Bore:                       Through hole  
                               Blind bore
- Machining method:     wet     dry  
                               min.lubrication
- Coolant supply:         Ext.                       Int.

- Grey cast iron  
 Alloyed grey cast iron  
 Aluminium (Si content > 10 %)  
 Aluminium (Si content < 10 %)  
 Copper  
 Brass  
 Bronze  
 \_\_\_\_\_



Hardness (HRC, HB, etc.): \_\_\_\_\_ Tensile strength (N/mm<sup>2</sup>): \_\_\_\_\_ Standard: \_\_\_\_\_ Standard No.: \_\_\_\_\_



MAPAL code (e.g. M2603, if known): \_\_\_\_\_

Cutting direction:     R.H.     L.H.  
(if not stated we will assume R.H.)

Coating:  
(if you wish to choose yourself)

- MxF  
 MxH  
 TiAlN  
 uncoated  
 \_\_\_\_\_

Shank form:

- HA (DIN 6535) 
- HB (DIN 6535) 
- HE (DIN 6535) 

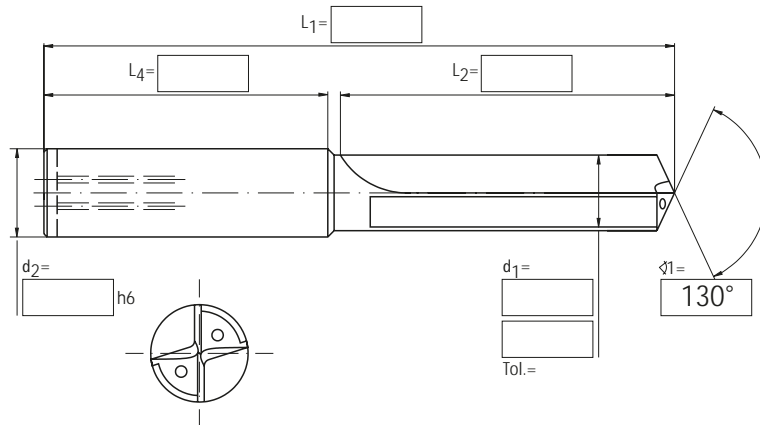

\_\_\_\_\_ Date                      Signature

Please do not write in this box, which will be completed by MAPAL specialists.

- |  |  |   |
|--|--|---|
| Groove form: <input type="checkbox"/> GG<br><input type="checkbox"/> ALU<br><input type="checkbox"/> _____ | Coating: <input type="checkbox"/> MxF<br><input type="checkbox"/> MxH<br><input type="checkbox"/> TiAlN<br><input type="checkbox"/> uncoated<br><input type="checkbox"/> _____ | Radial land on face: <input type="checkbox"/> Radial land on taper surface<br><input type="checkbox"/> Radial land on 4 faces<br><input type="checkbox"/> Round point |
|--|--|---|

Blank (MC): \_\_\_\_\_