

Solid carbide drill, straight fluted (double diameter)



Please copy, complete and return (only 1 tool per enquiry questionnaire/order).

Enquiry Order

MAPAL Inc.
4032 Dove Road
48060 Port Huron MI
USA
Phone +1 / 8 10 / 3 64 80 20
Fax +1 / 8 10 / 3 64 47 50
info@us.mapal.com
www.mapal.us

Company _____		Customer number (if available) _____
Contact partner _____	Tel./Fax _____	E-Mail _____
Address _____		

Number of drills _____ Delivery date required (non-binding) _____ Week

Please describe your machining task for us and the special tool you require:

Type of machining:

Bore: Through hole Blind bore

Machining method: wet dry
 min.lubrication

Coolant supply: Ext. Int.

Material to be machined:

- Grey cast iron
- Alloyed grey cast iron
- Aluminium (Si content > 10 %)
- Aluminium (Si content < 10 %)
- Copper
- Brass
- Bronze
- _____

Hardness (HRC, HB, etc.): _____ Tensile strength (N/mm²): _____ Standard: _____ Standard No.: _____

MAPAL code (e.g. M2603, if known): _____

Cutting direction: R.H. L.H.
(if not stated we will assume R.H.)

Coating:
(if you wish to choose yourself)

- MxF
- MxH
- TiAlN
- uncoated
- _____

Shank form:

- HA (DIN 6535)
- HB (DIN 6535)
- HE (DIN 6535)

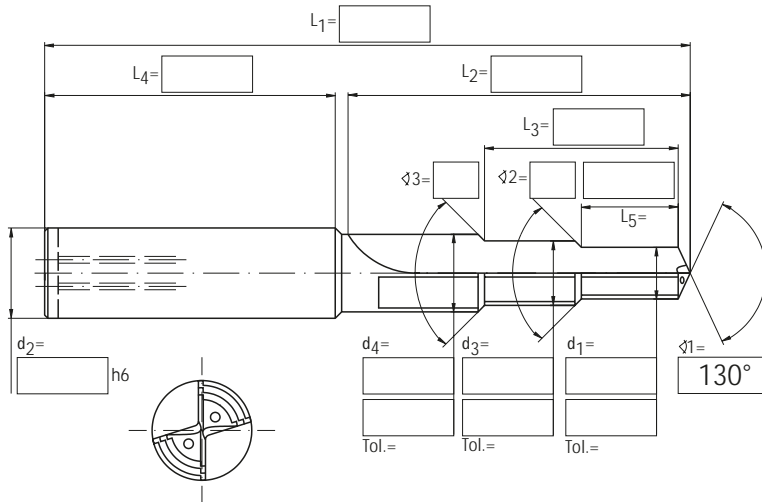

Date _____ Signature _____

Please do not write in this box, which will be completed by MAPAL specialists.

Groove form: <input type="checkbox"/> GG <input type="checkbox"/> ALU <input type="checkbox"/> _____	Coating: <input type="checkbox"/> MxF <input type="checkbox"/> MxH <input type="checkbox"/> TiAlN <input type="checkbox"/> uncoated <input type="checkbox"/> _____	Radial land on face: <input type="checkbox"/> Radial land on taper surface <input type="checkbox"/> Radial land on 4 faces <input type="checkbox"/> Round point
--	--	---

Blank (MC): _____