

PCD high performance drill (without step)

Please copy, complete and return (only 1 tool per enquiry questionnaire/order).



Enquiry Order

Company		Customer number (if available)
Contact partner	Tel./Fax	E-Mail
Address		

MAPAL Inc.
4032 Dove Road
48060 Port Huron MI
USA
Phone +1 / 8 10 / 3 64 80 20
Fax +1 / 8 10 / 3 64 47 50
info@us.mapal.com
www.mapal.us

Number of drills _____ Delivery date required (non-binding) _____ Week

Please describe your machining task for us and the special tool you require:

Material to be machined:

Bore: Through hole
 Blind bore

- Aluminium (Si content > 10 %)
- Aluminium (Si content < 10 %)
- Brass
- Bronze

Machining method: wet dry
 min.lubrication

Coolant supply: Ext. Int.



Hardness (HRC, HB, etc.): _____ Tensile strength (N/mm²): _____ Standard: _____ Standard No.: _____

MAPAL code (e.g. M2913, if known):

Cutting direction: R.H. L.H.
(if not stated we will assume R.H.)

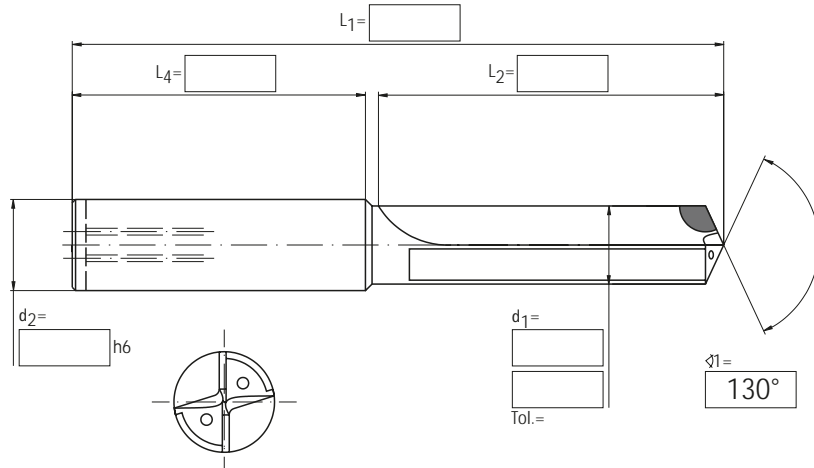

Shank form:

- HA (DIN 6535)
- HB (DIN 6535)
- HE (DIN 6535)

Date _____ Signature _____

Please do not write in this box, which will be completed by MAPAL specialists.

Groove form: ALU

Radial land on face: Radial land on 4 faces
 Round point

Blank (MC): _____