

MAPAL tangential fine boring tools TFB

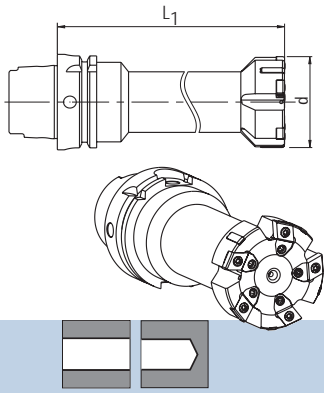

TFB 100

for blind holes

TFB 110

for through holes

Ø 60-
100 mm
Monoblock
design

TFB 100 Diameter d	TFB 110 Diameter d	Tool length L ₁	Insert		Accessories*		
			Size	Qty.	Clamping Torx screw Order No. (Size)	Adjusting wedge Order No.	Threaded spindle Order No.
60 - 69,99	60 - 69,99		FTXW 0905...B030 Page 19	5	TX-M3,5x11 10048466 (TORX-T9)	K14884-153	10072872
70 - 89,99	70 - 89,99		FTXW 0905...B030 Page 19	6	TX-M3,5x11 10048466 (TORX-T9)	K14884-153	10072872
90 - 100	90 - 100		FTXW 0905...B030 Page 20	8	TX-M3,5x11 10048466 (TORX-T9)	K14884-153	10072872

↓
Please note: The max. tool length must comply with size of machine connection! (see diagram page 24)

TFB 100

TFB 110

Machine
connections

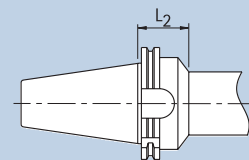
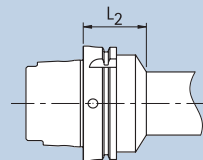

Diameter d	Size	HSK-A		HSK-C		ISO-AD			ISO-B	
		L ₂	Code	L ₂	Code	Size	L ₂	Code	L ₂	Code
60 - 100	63	47	A63	20	A63	40	40	AD40	40	B40
	80	47	A80	25	A80	50	45	AD50	45	B50
	100	55	A100	30	A100	-	-	-	-	-

* Supply of the tools includes the clamping screws and adjusting devices.

Order examples see page 23

Sizes in mm.