

# MAPAL indexable inserts

## M grade – standard

### CCMT

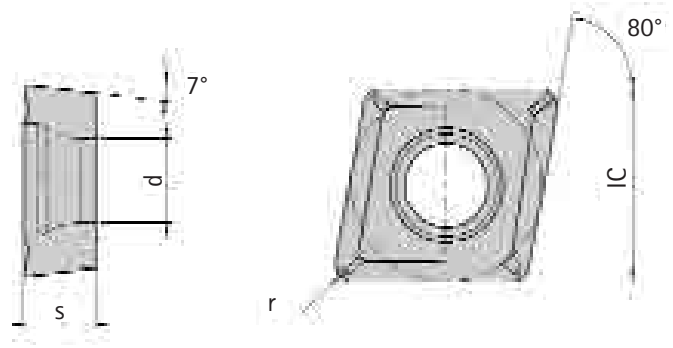

| Reference code | chipbreaker | IC mm | d mm | s mm | r mm | max<br>a <sub>p</sub><br>mm | Order description: Insert with order number |                 |                 | material  |
|----------------|-------------|-------|------|------|------|-----------------------------|---|-----------------|-----------------|-----------|
|                |             |       |      |      |      |                             | DSAF  | DSCF            | ESCF            |           |
| CCMT 060202 N  | -33         | 6,35  | 2,8  | 2,38 | 0,2  | 1,7                         |   |                 | <b>10061391</b> | steel     |
| CCMT 09T304 N  | -33         | 9,525 | 4,4  | 3,97 | 0,4  | 2                           |   |                 | <b>10061392</b> |           |
| CCMT 09T308 N  | -34         | 9,525 | 4,4  | 3,97 | 0,8  | 0,8                         |   |                 | <b>10026967</b> |           |
| CCMT 120408 N  | -34         | 12,7  | 5,5  | 4,76 | 0,8  | 3,6                         |   |                 | <b>10061393</b> |           |
| CCMT 120412 N  | -34         | 12,7  | 5,5  | 4,76 | 1,2  | 3,6                         |   |                 | <b>10061394</b> |           |
| CCMT 060204 N  | -73         | 6,35  | 2,8  | 2,38 | 0,4  | 1,7                         | <b>10026974</b>                             |                 |                 | cast iron |
| CCMT 09T304 N  | -73         | 9,525 | 4,4  | 3,97 | 0,4  | 2                           | <b>10045117</b>                             | <b>10061397</b> |                 |           |
| CCMT 09T308 N  | -74         | 9,525 | 4,4  | 3,97 | 0,8  | 3                           | <b>10046040</b>                             | <b>10026975</b> |                 |           |
| CCMT 120408 N  | -74         | 12,7  | 5,5  | 4,76 | 0,8  | 3,6                         | <b>10034846</b>                             | <b>10047155</b> |                 |           |
| CCMT 120412 N  | -74         | 12,7  | 5,5  | 4,76 | 1,2  | 3,6                         |   | <b>10061398</b> |                 |           |

Ordering example: 50 off inserts – order no. 10026974  
or  
50 off inserts CCMT060204N-73DSAF

### Clamping screw for inserts

| insert size   | torx screw | torx screwdriver | order no. | torque value (Nm) |
|---------------|------------|------------------|-----------|-------------------|
| SP __ 0603 __ | M2,5x6     | T8               | 10019600  | 0,8               |
| SC __ 09T3 __ | M3,5x9     | T15              | 10017389  | 2,5               |
| SC __ 1204 __ | M5x11      | T20              | 10059857  | 5                 |
| CC __ 0602 __ | M2,5x6     | T8               | 10019600  | 0,8               |
| CC __ 09T3 __ | M3,5x9     | T15              | 10017389  | 2,5               |
| CC __ 1204 __ | M5x11      | T20              | 10059857  | 5                 |
| TC __ 0902 __ | M2,2x5,5   | T7               | 10018764  | 0,6               |
| TC __ 1102 __ | M2,5x6     | T8               | 10019600  | 0,8               |