

# MEGA-Drill-Inox, alteration to standard product



Please copy, complete and return (only 1 tool per enquiry/questionnaire/order).

Request                       Order

Company _____		Customer number (if available) _____
Contact partner _____	Tel./Fax _____	E-Mail _____
Address _____		

**MAPAL Inc.**  
 4032 Dove Road  
 48060 Port Huron MI  
 USA  
 Phone +1 / 8 10 / 3 64 80 20  
 Fax +1 / 8 10 / 3 64 47 50  
 sc-tools@us.mapal.com  
 www.mapal.us

Number of drills \_\_\_\_\_ Delivery date required (non-binding) \_\_\_\_\_ Week \_\_\_\_\_

Please describe your machining task for us and the special tool you require:

**Material to be machined:**

Bore:

- Through hole  
 Blind bore

Machining method:

- wet     dry  
 min.lubrication

Coolant supply:

- Ext.                       Int.  
                      

- |                                                         |                                                        |
|---------------------------------------------------------|--------------------------------------------------------|
| <input type="checkbox"/> Unalloyed steel                | <input type="checkbox"/> Aluminium (Si content > 10 %) |
| <input type="checkbox"/> Cast steel                     | <input type="checkbox"/> Aluminium (Si content < 10 %) |
| <input type="checkbox"/> Alloyed steel                  | <input type="checkbox"/> Copper                        |
| <input type="checkbox"/> Inox                           | <input type="checkbox"/> Brass                         |
| <input type="checkbox"/> Stainless/acid-resistant steel | <input type="checkbox"/> Bronze                        |
| <input type="checkbox"/> Grey cast iron                 | <input type="checkbox"/> Titanium alloys               |
| <input type="checkbox"/> Alloyed grey cast iron         | <input type="checkbox"/> Nickel alloys                 |
| <input type="checkbox"/> Nodular iron                   | <input type="checkbox"/> _____                         |
| <input type="checkbox"/> CGI                            |                                                        |
| <input type="checkbox"/> Malleable iron                 |                                                        |

Hardness (HRC, HB, etc.): \_\_\_\_\_ Tensile strength (N/mm<sup>2</sup>): \_\_\_\_\_ Standard: \_\_\_\_\_ Standard No.: \_\_\_\_\_

MAPAL code (e.g. M1803): \_\_\_\_\_

Cutting direction:  R.H.     L.H.  
 (if not stated we will assume R.H.)



Coating:

(if you wish to choose yourself)

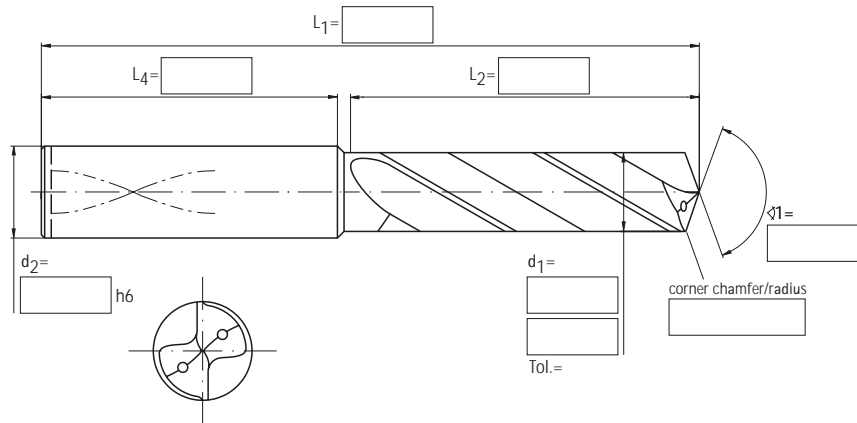
- MxF  
 MxH  
 TiAlN  
 uncoated  
 \_\_\_\_\_



Shank form:

- HA (DIN 6535)   
 HB (DIN 6535)   
 HE (DIN 6535) 

\_\_\_\_\_  
 Date                      Signature

Please do not write in this box, which will be completed by MAPAL specialists.

- |                                                                                                                                                                              |                                                                                                                                                                                |                                                                                                                                                                                                                |
|------------------------------------------------------------------------------------------------------------------------------------------------------------------------------|--------------------------------------------------------------------------------------------------------------------------------------------------------------------------------|----------------------------------------------------------------------------------------------------------------------------------------------------------------------------------------------------------------|
| Groove form: <input type="checkbox"/> MEGA<br><input type="checkbox"/> GG<br><input type="checkbox"/> ALU<br><input type="checkbox"/> INOX<br><input type="checkbox"/> _____ | Coating: <input type="checkbox"/> MxF<br><input type="checkbox"/> MxH<br><input type="checkbox"/> TiAlN<br><input type="checkbox"/> uncoated<br><input type="checkbox"/> _____ | Radial land on face: <input type="checkbox"/> Radial land on taper surface<br><input type="checkbox"/> Radial land on 4 faces<br><input type="checkbox"/> Round point<br><input type="checkbox"/> Spiral point |
|------------------------------------------------------------------------------------------------------------------------------------------------------------------------------|--------------------------------------------------------------------------------------------------------------------------------------------------------------------------------|----------------------------------------------------------------------------------------------------------------------------------------------------------------------------------------------------------------|

Blank (MC): \_\_\_\_\_